

2014



COUNTERTOP BRACKETS

COUNTERTOP BRACKETS

Pgs. 388-401

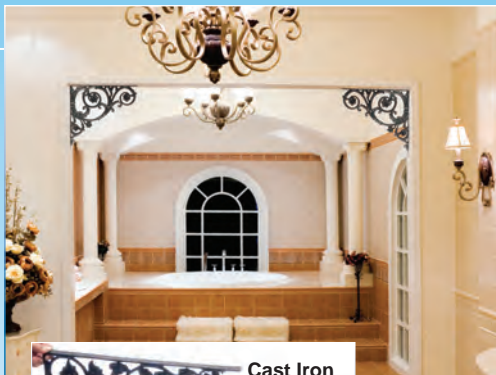

Cast Iron & Cast Aluminum

BRACKETS



Shelf Center Supports

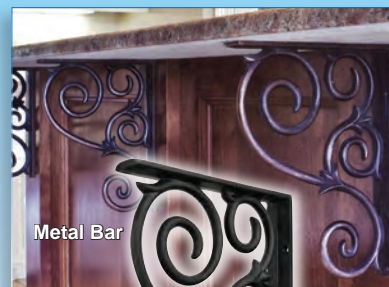

Metal Bar



Countertop Supports (Steel)

SUPPORTS



Dynamo

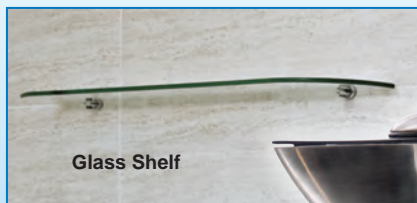

Glass Shelf



UV Glass

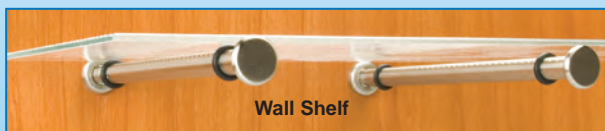

Wall Shelf

Onlay



BRACKETS

Cast Iron & Aluminum (Decorative).....	388-389
Countertop Support (Steel).....	390-394
Folding Shelf.....	395
Metal Bar.....	396-397
Shelf Center Supports (Plastic).....	395
Shelf.....	395
Work Station.....	395

ONLAY (Metal).....

397

SUPPORTS (Countertop)

Countertop Supports (Dynamo-Solid Carbon Steel).....	398-399
Economy Countertop Supports.....	400
UV Glass Supports (Aluminum).....	400

SUPPORTS (Shelf & Wall Shelf)

Glass Shelf Supports.....	401
Wall Shelf Supports.....	401

SEE PAGES 1007-1023 FOR A - Z INDEX

CAST IRON & CAST ALUMINUM BRACKETS

Add the perfect finishing touch of charm, romance and elegance with our cast iron and aluminum brackets. These intricately detailed architectural elements lend visual interest and appeal to your interior or exterior setting.

CAST IRON

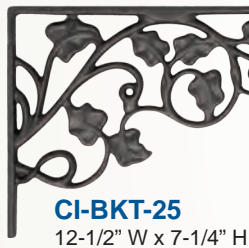

ALL BRACKETS HAVE A 5/8" THICKNESS UNLESS NOTED

ALL MEASUREMENTS ARE APPROXIMATE

Cast iron can be drilled using a 3/16" HSS (High Speed Steel) drill bit to start, then switching to a larger bit that coordinates with the intended hole size. Brackets do not have pre-drilled mounting holes.

Brackets are unfinished. Clean, prime and paint with a metal clad paint. For exterior applications, use clear coat after painting.

CAST IRON & CAST ALUMINUM BRACKETS

CAST IRON



CI-BKT-60
17-3/4" W x 14-1/4" H



CI-BKT-65
18-1/4" W x 18-1/4" H



For photographic purposes product has been painted.

**ALL BRACKETS HAVE
A 5/8" THICKNESS
UNLESS NOTED**

**ALL MEASUREMENTS
ARE APPROXIMATE**



CI-BKT-70
20-3/4" W x 20-3/4" H



CI-BKT-75
21" W x 21" H



CI-BKT-80
23" W x 8-3/16" H
1/2" THICKNESS



CI-BKT-85
28-5/8" W x 9-5/8" H



CI-BKT-90
29" W x 10-3/4" H

Cast iron can be drilled using a 3/16" HSS (High Speed Steel) drill bit to start, then switching to a larger bit that coordinates with the intended hole size. Brackets do not have pre-drilled mounting holes.

Brackets are unfinished. Clean, prime and paint with a metal clad paint. For exterior applications, use clear coat after painting.

CAST ALUMINUM



CAL-BKT-5
15" W x 15" H



CAL-BKT-10
15-3/8" W x 15-3/8" H



CAL-BKT-15
15-3/4" W x 15-3/4" H



CAL-BKT-20
22" W x 12-1/4" H

Cast aluminum brackets have weld tabs.

STEEL COUNTERTOP SUPPORT BRACKETS

When purchasing supports for countertops the discerning customer wants a high quality piece, beautifully designed with outstanding strength. We present all these characteristics in our line of countertop brackets and corbels, also incorporating metal design expertise with ISO 9001:2008 certified manufacturing procedures to create unique supports made out of quality materials.

Available In: 1008 Cold Rolled Steel / Raw (treated for customer's own painting or finishing) or 304 Stainless Steel
Thickness: 1/4" (Except Where Noted) **Flange Width:** 2"- 3" **Hole Size:** Fits standard 1/4" screws/bolts

The brackets have a load rating of over 1000 pounds per pair

Finishes Available:

304 Stainless Steel (Brushed #4) – SS
 1008 Cold Rolled Steel (Raw) – CRS

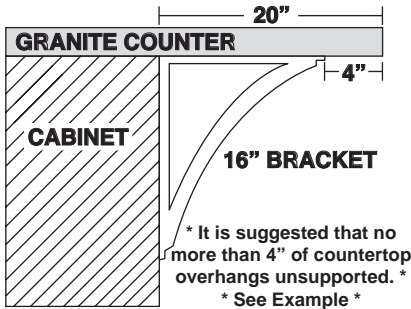

FLOATING COUNTERTOP SUPPORT BRACKETS

Our New Jersey, New York & Maine brackets create a floating countertop appearance with the solid strength of metal support. They give the maximum leg room, liberating you from the annoying knee knocking in cramped spaces. New Jersey brackets are best installed on the support studs in a knee wall. New York & Maine brackets are best installed on the top plate of a knee wall.

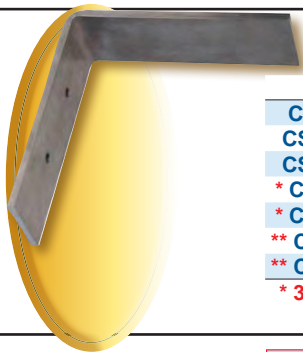

NEW JERSEY

PART #	FINISH	SIZE
CSB8-NJ-CRS	CRS	8x8
CSB10-NJ-CRS	CRS	10x10
CSB12-NJ-CRS	CRS	12x12
* CSB14-NJ-CRS	CRS	14x14
* CSB16-NJ-CRS	CRS	16x16
** CSB18-NJ-CRS	CRS	18x18
** CSB20-NJ-CRS	CRS	20x20
* 3/8" Thick		** 1/2" Thick



Made In USA

All our countertop brackets are designed and produced in the United States of America. We manufacture the best supports on the market and are honored to service your countertop requirements. When ordering from us, you can know that your corbels will be produced with quality in mind and your satisfaction as the highest priority.

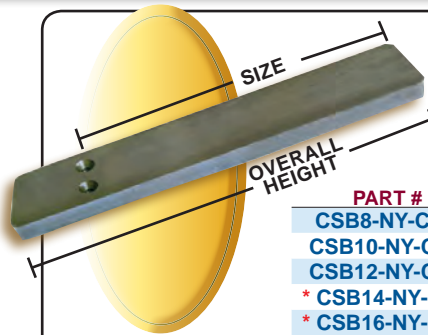

NEW YORK

PART #	FINISH	SIZE	OVERALL HEIGHT
CSB8-NY-CRS	CRS	10"	12"
CSB10-NY-CRS	CRS	12"	14"
CSB12-NY-CRS	CRS	14"	16"
* CSB14-NY-CRS	CRS	16"	18"
* CSB16-NY-CRS	CRS	18"	20"
* CSB18-NY-CRS	CRS	20"	22"
** CSB20-NY-CRS	CRS	22"	24"
* 3/8" Thick		** 1/2" Thick	

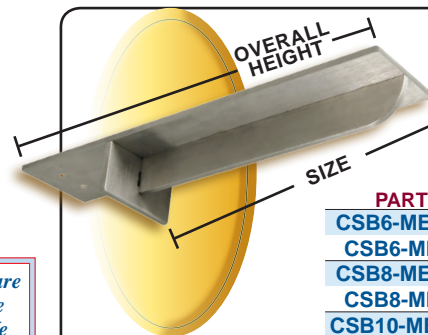

MAINE

PART #	FINISH	SIZE	OVERALL HEIGHT
CSB6-ME-CRS	CRS	6"	10"
CSB6-ME-SS	SS	6"	10"
CSB8-ME-CRS	CRS	8"	12"
CSB8-ME-SS	SS	8"	12"
CSB10-ME-CRS	CRS	10"	14"
CSB10-ME-SS	SS	10"	14"
CSB12-ME-CRS	CRS	12"	16"
CSB12-ME-SS	SS	12"	16"
CSB16-ME-CRS	CRS	16"	20"
CSB16-ME-SS	SS	16"	20"
CSB20-ME-CRS	CRS	20"	24"
CSB20-ME-SS	SS	20"	24"

STEEL COUNTERTOP SUPPORT BRACKETS

Available In: 1008 Cold Rolled Steel / Raw (treated for customer's own painting or finishing) or 304 Stainless Steel
Thickness: 1/4" (Except Where Noted) **Flange Width:** 2"- 3" **Hole Size:** Fits standard 1/4" screws/bolts

Finishes Available:

304 Stainless Steel (Brushed #4) – SS
 1008 Cold Rolled Steel (Raw) – CRS

The brackets have a load rating of over 1000 pounds per pair

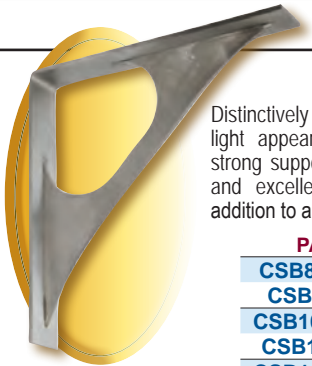
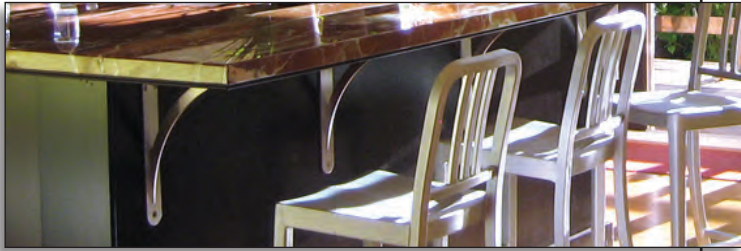

ALABAMA

Distinctively beautiful. The cutout gusset gives a light appearance while the countertop provides strong support to your granite. It's built with pride and excellent quality detail. A great hardware addition to any kitchen, bath or even office!

PART #	FINISH	SIZE
CSB8-AL-CRS	CRS	8x8
CSB8-AL-SS	SS	8x8
CSB10-AL-CRS	CRS	10x10
CSB10-AL-SS	SS	10x10
CSB12-AL-CRS	CRS	12x12
CSB12-AL-SS	SS	12x12
CSB14-AL-CRS	CRS	14x14
CSB14-AL-SS	SS	14x14
CSB16-AL-CRS	CRS	16x16
CSB16-AL-SS	SS	16x16
CSB18-AL-CRS	CRS	18x18
CSB18-AL-SS	SS	18x18
CSB20-AL-CRS	CRS	20x20
CSB20-AL-SS	SS	20x20
CSB24-AL-CRS	CRS	24x24
CSB24-AL-SS	SS	24x24



NEW HAMPSHIRE

A unique style—from the rounded foot to the straight gusset with holes reminiscent of Orion's belt. These brackets are the perfect fit for computer rooms, stylish restaurants, offices or just about anywhere you'd want, it will always look great.

PART #	FINISH	SIZE
CSB8-NH-CRS	CRS	8x8
CSB8-NH-SS	SS	8x8
CSB10-NH-CRS	CRS	10x10
CSB10-NH-SS	SS	10x10
CSB12-NH-CRS	CRS	12x12
CSB12-NH-SS	SS	12x12

IDAHO

A popular design, the decorative, curved gusset on the bracket makes for a very attractive support while giving good leg room. The gusset extends through the flanges of the brace to allow for welding on the backside of the support, giving no visible weld on the face. With a strong support capacity and an elegant appearance, these are great for all kitchen, bath and other decorative applications.

PART #	FINISH	SIZE
CSB8-ID-CRS	CRS	8x8
CSB8-ID-SS	SS	8x8
CSB10-ID-CRS	CRS	10x10
CSB10-ID-SS	SS	10x10
CSB12-ID-CRS	CRS	12x12
CSB12-ID-SS	SS	12x12
CSB14-ID-CRS	CRS	14x14
CSB14-ID-SS	SS	14x14
CSB16-ID-CRS	CRS	16x16
CSB16-ID-SS	SS	16x16
CSB18-ID-CRS	CRS	18x18
CSB18-ID-SS	SS	18x18
CSB20-ID-CRS	CRS	20x20
CSB20-ID-SS	SS	20x20
CSB24-ID-CRS	CRS	24x24
CSB24-ID-SS	SS	24x24

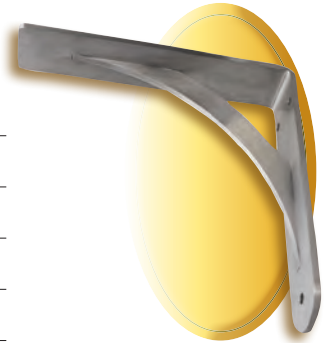

GEORGIA

The perfect blend of elegant design and solid strength. The wavy gusset gives the illusion of movement even while easily supporting your countertop application. This corbel is a perfect complement to a beach front home, however it looks and works great under a countertop, bar or window ledge in any geographical location.

PART #	FINISH	SIZE
CSB8-GA-CRS	CRS	8x8
CSB8-GA-SS	SS	8x8
CSB10-GA-CRS	CRS	10x10
CSB10-GA-SS	SS	10x10
CSB12-GA-CRS	CRS	12x12
CSB12-GA-SS	SS	12x12
CSB14-GA-CRS	CRS	14x14
CSB14-GA-SS	SS	14x14
CSB16-GA-CRS	CRS	16x16
CSB16-GA-SS	SS	16x16

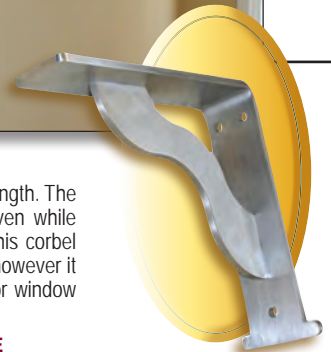

STEEL COUNTERTOP SUPPORT BRACKETS

Available In: 1008 Cold Rolled Steel / Raw (treated for customer's own painting or finishing) or 304 Stainless Steel
Thickness: 1/4" (Except Where Noted) **Flange Width:** 2"- 3" **Hole Size:** Fits standard 1/4" screws/bolts

The brackets have a load rating of over 1000 pounds per pair

Finishes Available:

304 Stainless Steel (Brushed #4) – SS
 1008 Cold Rolled Steel (Raw) – CRS

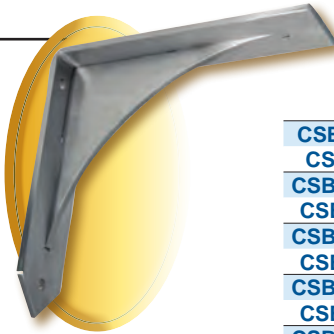

CALIFORNIA

PART #	FINISH	SIZE
CSB8-CA-CRS	CRS	8x8
CSB8-CA-SS	SS	
CSB10-CA-CRS	CRS	10x10
CSB10-CA-SS	SS	
CSB12-CA-CRS	CRS	12x12
CSB12-CA-SS	SS	
CSB14-CA-CRS	CRS	14x14
CSB14-CA-SS	SS	
CSB16-CA-CRS	CRS	16x16
CSB16-CA-SS	SS	
CSB18-CA-CRS	CRS	18x18
CSB18-CA-SS	SS	
CSB20-CA-CRS	CRS	20x20
CSB20-CA-SS	SS	
CSB24-CA-CRS	CRS	24x24
CSB24-CA-SS	SS	

A strong, solid support with an attractive touch. This support is unique in that it has a solid gusset for that extra support and an arrow shaped foot. This support is stylish fit in any kitchen or other application at your business or home.



RHODE ISLAND

PART #	FINISH	SIZE
CSB8-RI-CRS	CRS	8x8
CSB8-RI-SS	SS	
CSB10-RI-CRS	CRS	10x10
CSB10-RI-SS	SS	
CSB12-RI-CRS	CRS	12x12
CSB12-RI-SS	SS	
CSB14-RI-CRS	CRS	14x14
CSB14-RI-SS	SS	
CSB16-RI-CRS	CRS	16x16
CSB16-RI-SS	SS	
CSB18-RI-CRS	CRS	18x18
CSB18-RI-SS	SS	
CSB20-RI-CRS	CRS	20x20
CSB20-RI-SS	SS	
CSB24-RI-CRS	CRS	24x24
CSB24-RI-SS	SS	

The Rhode Island design is a modern approach to a straight gusseted countertop brace. We have turned the stiffener welded between the two flanges of the bracket so that the width of the gusset is aligned with that of the flanges. These supports have a wonderful modern appeal while providing the heavy duty support strength.



VIRGINIA

The Virginia design presents strong supports with a classic appeal. They are designed with a straight gusset that acts as a stiffener against deflection under heavy load applications.

PART #	FINISH	SIZE
CSB8-VA-CRS	CRS	8.5x6
CSB8-VA-SS	SS	
CSB10-VA-CRS	CRS	10x8
CSB10-VA-SS	SS	
CSB12-VA-CRS	CRS	12x10
CSB12-VA-SS	SS	

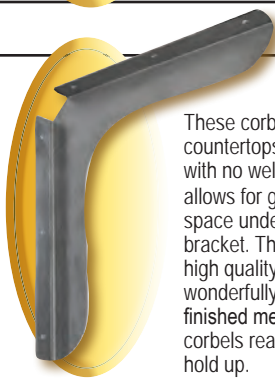

NORTH CAROLINA

These corbels are made of 1/4" steel for heavy duty support of your countertops. This corbel design has a curved shape that is formed with no weldment and while giving an attractive appearance also allows for great space under the bracket. These high quality, wonderfully finished metal corbels really hold up.

PART #	FINISH	SIZE
CSB8-NC-CRS	CRS	8x8
CSB8-NC-SS	SS	
CSB10-NC-CRS	CRS	10x10
CSB10-NC-SS	SS	
CSB12-NC-CRS	CRS	12x12
CSB12-NC-SS	SS	
CSB14-NC-CRS	CRS	14x14
CSB14-NC-SS	SS	
CSB16-NC-CRS	CRS	16x16
CSB16-NC-SS	SS	
CSB18-NC-CRS	CRS	18x18
CSB18-NC-SS	SS	
CSB20-NC-CRS	CRS	20x20
CSB20-NC-SS	SS	

SOUTH CAROLINA

If you are looking for a low profile with a high capacity support, you have come to the right place. These are designed using a solid gusset to provide additional resistance against deflection.

PART #	FINISH	SIZE
CSB8-SC-CRS	CRS	8x8
CSB8-SC-SS	SS	
CSB10-SC-CRS	CRS	10x10
CSB10-SC-SS	SS	
CSB12-SC-CRS	CRS	12x12
CSB12-SC-SS	SS	
CSB14-SC-CRS	CRS	14x14
CSB14-SC-SS	SS	
CSB16-SC-CRS	CRS	16x16
CSB16-SC-SS	SS	
CSB18-SC-CRS	CRS	18x18
CSB18-SC-SS	SS	
CSB20-SC-CRS	CRS	20x20
CSB20-SC-SS	SS	
CSB24-SC-CRS	CRS	24x24
CSB24-SC-SS	SS	

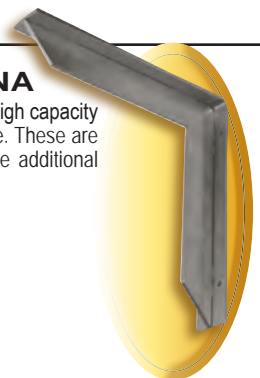

STEEL COUNTERTOP SUPPORT BRACKETS

Available In: 1008 Cold Rolled Steel / Raw (treated for customer's own painting or finishing) or 304 Stainless Steel
Thickness: 1/4" (Except Where Noted) **Flange Width:** 2"- 3" **Hole Size:** Fits standard 1/4" screws/bolts

The brackets have a load rating of over 1000 pounds per pair

Finishes Available:

304 Stainless Steel (Brushed #4) – SS
 1008 Cold Rolled Steel (Raw) – CRS

COLORADO

The Colorado is a countertop support with a little bit of flair in a gusset design that is sleek and curvy on both the outside and the inside. The gusset attaches to each flange of this support, which are rounded off at the ends, accenting the style of the gusset. Available in sizes to support countertop overhangs ranging from 10" to 22".



PART #	FINISH	SIZE
CSB8-CO-CRS	CRS	8x8
CSB8-CO-SS	SS	
CSB10-CO-CRS	CRS	10x10
CSB10-CO-SS	SS	
CSB12-CO-CRS	CRS	12x12
CSB12-CO-SS	SS	
CSB14-CO-CRS	CRS	14x14
CSB14-CO-SS	SS	
CSB18-CO-CRS	CRS	18x18
CSB18-CO-SS	SS	

ELEVATED COUNTERTOP MOUNTED SUPPORT BRACKETS



LOUISIANA

The Louisiana, featuring a teardrop foot plate and a stylish gusset, bolts directly to the top of your counter or surface to elevate a top counter. Together these aspects create a durable support, capable of holding heavy stone or glass counters up to 18" wide. Available in 6", 8" and 10" elevations.

PART #	FINISH	SIZE ELEVATES	TOP PLATE
CSB6-LA-CRS	CRS	6"	10x2
CSB6-LA-SS	SS		
CSB8-LA-CRS	CRS	8"	10x2
CSB8-LA-SS	SS		
CSB10-LA-CRS	CRS	10"	10x2
CSB10-LA-SS	SS		

NEVADA

The Nevada is an elevated support that mounts directly to the top of your counter. With a rounded - diamond shaped foot plate and a decorative, concave - style gusset that flares at the top, it solidly supports a dramatic heavy stone or glass floating countertop up to 18" wide. Available in 6", 8" and 10" elevations.



PART #	FINISH	SIZE ELEVATES	TOP PLATE
CSB6-NV-CRS	CRS	6"	10x2
CSB6-NV-SS	SS		
CSB8-NV-CRS	CRS	8"	10x2
CSB8-NV-SS	SS		
CSB10-NV-CRS	CRS	10"	10x2
CSB10-NV-SS	SS		

** Please specify if using elevated brackets to support a glass counter top.**

STEEL COUNTERTOP SUPPORT BRACKETS

Available In: 1008 Cold Rolled Steel / Raw (treated for customer's own painting or finishing) or 304 Stainless Steel
Thickness: 1/4" (Except Where Noted) **Flange Width:** 2"- 3" **Hole Size:** Fits standard 1/4" screws/bolts

The brackets have a load rating of over 1000 pounds per pair

Finishes Available:

304 Stainless Steel (Brushed #4) – SS
 1008 Cold Rolled Steel (Raw) – CRS

ELEVATED SUPPORT BRACKETS

TEXAS

This premium mount has a weighty appearance and customized shape, which is sure to make an impression of quality.

PART #	FINISH	SIZE
CSB20-TX-CRS	CRS	20x12
CSB20-TX-SS	SS	



NEW MEXICO

The New Mexico design is shaped to provide the appearance of a floating countertop offset with the counter. Multiple plates on the ends of the solid bar gusset provide for fixture on the stud wall or reinforced cabinetry.

PART #	FINISH	SIZE
CSB8-NM-CRS	CRS	8.1x11.4
CSB8-NM-SS	SS	
CSB12-NM-CRS	CRS	11x11
CSB12-NM-SS	SS	



ARIZONA

These brackets are designed for the elevated application and enhance the finest of kitchens. The Arizona support's smooth contours and serpentine profile gives this support a character all of its own.

PART #	FINISH	SIZE
CSB10-AZ-CRS	CRS	10x10
CSB10-AZ-SS	SS	
CSB12-AZ-CRS	CRS	12x20
CSB12-AZ-SS	SS	

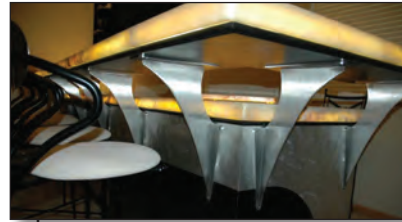

MONTANA

An elevated countertop support bracket, the Montana Design, mounted to a cabinet or wall, is shaped to support a heavy stone or glass bar up to 12" wide. The stainless steel version matches the look and feel any other stainless steel features in your room, such as appliances or railing.

PART #	FINISH	SIZE
CSB11-MT-CRS	CRS	11x11
CSB11-MT-SS	SS	



MASSACHUSETTS

This is a very versatile corbel. It has an aesthetically pleasing appearance built for supporting elevated countertops, but looks great when attached to a standard countertop as a stylish end-piece support. Truly a masterpiece in metal.

PART #	FINISH	SIZE
CSB8-MA-CRS	CRS	8x8
CSB8-MA-SS	SS	
CSB10-MA-CRS	CRS	10x10
CSB10-MA-SS	SS	
CSB12-MA-CRS	CRS	12x12
CSB12-MA-SS	SS	



** Please specify if using elevated brackets to support a glass counter top.**

BRACKETS / SUPPORTS

Work Station Brackets 1000 lbs. Per Bracket (On All Sizes)

Width & Height of the bracket are reversible. Brackets come with pre-drilled screw holes on both sides.



AVAILABLE IN 4 FORMICA MATCHED FINISHES:
 • BLACK (*BK) FORMICA #909-58, • WHITE (*WH) FORMICA #933-58, • GRAY (*GY) FORMICA #961-58,
 • ALMOND (*AL) FORMICA #920-58

- High quality 1/8" steel
- 1-1/2" Forms with multiple 1/4" mounting holes per side
- Larger sizes have a 3" x 3" x 45° notch to allow for wall cleat and wire clearance
- Screws *not* included

PART #	SIZE	CTN QTY
WSB-58-*	5" x 8"	5 pairs
WSB-812-*	8" x 12"	5 pairs
WSB-1218-*	12" x 18"	3 pairs
WSB-1521-*	15" x 21"	3 pairs
WSB-1824-*	18" x 24"	3 pairs
WSB-2424-*	24" x 24"	3 pairs
WSB-2429-*	24" x 29"	2 pairs

SHELF CENTER SUPPORTS

Vanguard®

CONTEMPORARY DESIGN



- ABS plastic
- Use with 12", 14" and 16" deep shelves
- Designed to support 150 lbs. when back plate is installed directly into a stud - REQUIRED
- Unique back plate conceals all screws
- Recommended spacing of every 36" to 48", as long as mounted to a stud

CONTEMPORARY DESIGN

PART #	COLOR	CARTON QTY.
VG-700-634C-WH	White	20
VG-700-634C-CP	Chocolate Pearwood	pieces

**For Our Full Line Of Vanguard Products,
See Pages 379-381**

FOLDING SHELF BRACKETS

WHITE ENAMEL EPOXY PAINTED FINISH

- For drop down shelves from 8" to 24" in width
- Automatic safety locking device
- Quick release folding mechanism
- Solid rivet construction

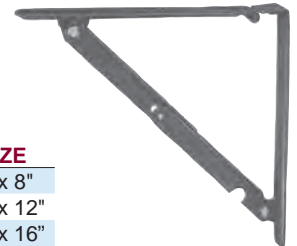

PART #	SIZE
SH-80-WH	8" x 8"
SH-120-WH	12" x 12"
SH-160-WH	16" x 16"

SHELF BRACKETS

GRAY OR WHITE ENAMEL PORCELAIN PAINTED FINISH

- Six screw holes in each bracket for greater stability
- One piece construction
- Heavy gauge .0354
- Smooth edge steel
- Center rib design for greater strength
- Staggered screw mounts
- Countersunk screw holes
- Screws *not* included



PART #	SIZE	WEIGHT CAPACITY
SHB-34-GY	3" x 4"	40 lbs.
SHB-34-WH	3" x 4"	40 lbs.
SHB-45-GY	4" x 5"	40 lbs.
SHB-45-WH	4" x 5"	40 lbs.
SHB-56-GY	5" x 6"	45 lbs.
SHB-56-WH	5" x 6"	45 lbs.
SHB-68-GY	6" x 8"	55 lbs.
SHB-68-WH	6" x 8"	55 lbs.
SHB-810-GY	8" x 10"	55 lbs.
SHB-810-WH	8" x 10"	55 lbs.
SHB-1012-GY	10" x 12"	65 lbs.
SHB-1012-WH	10" x 12"	65 lbs.
SHB-1214-GY	12" x 14"	75 lbs.
SHB-1214-WH	12" x 14"	75 lbs.

METAL BAR BRACKETS

New

Material: Cast Iron

With their graceful curves & scrolls cast iron metal bar brackets have a flowing movement that create an elegant design.



- Size: 10" x 13-1/2"
- Pre-drilled and ready to install
- Supplied with color match mounting screws (#8 x 3/4").
- A substantial 7 lbs. each
- For interior applications

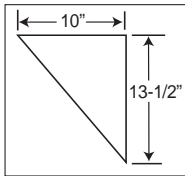

Flange Width



Black (*BLK)



Dark Brushed Antique Copper (*DBAC)

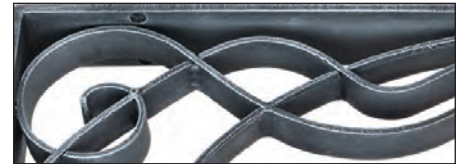

Swedish Iron Machined (*SIM)

1-1/2" Flange Width



MCOR1-*

Swedish Iron Machined
Not Available



MCOR2-*

Swedish Iron Machined
Not Available



MCOR3-*



MCOR4-*

Swedish Iron Machined
Not Available

METAL BAR BRACKETS

Material: Cast Iron

Size: 10" x 13-1/2"

New

Available in: Black (*BLK), Dark Brushed Antique Copper (*DBAC)
and Swedish Iron Machined (*SIM)

Supplied with mounting screws (#8 x 3/4") • 7 lbs. each

1-7/8" Flange Width



MCOR5-*



MCOR6-*



MCOR7-*

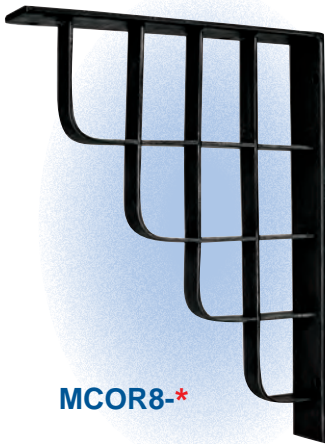

MCOR8-*



MCOR9-*



MCOR10-*

METAL ONLAY

Material: Cast Iron

Size: 25" x 5-3/8" x 1/2"

One design available in 2 finishes: Black (*BLK) and Dark Brushed Antique Copper (*DBAC)

MONL-01-*



CREATE SPACE AND STORAGE WITH STYLE!

MATERIAL = SOLID CARBON STEEL
Polished Chrome (PC) and Matte Chrome (MC)



STRAIGHT
Shown in
Matte Chrome

PRODUCT FEATURES:

- Variety of mounting options
- Ideal for wood or glass shelves

FINISHES GO WITH ANY DECOR



ANGLED
Shown in
Polished Chrome

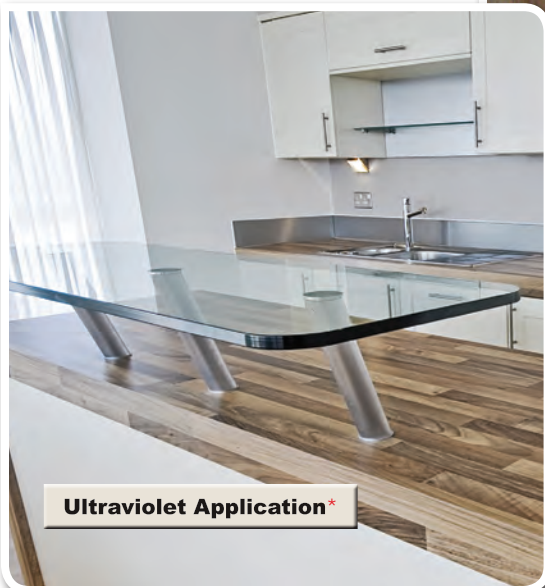

**Requires ultraviolet adhesive and gun*

"DYNAMO" COUNTERTOP SUPPORTS

1

Choose Barrel Type

ANGLED

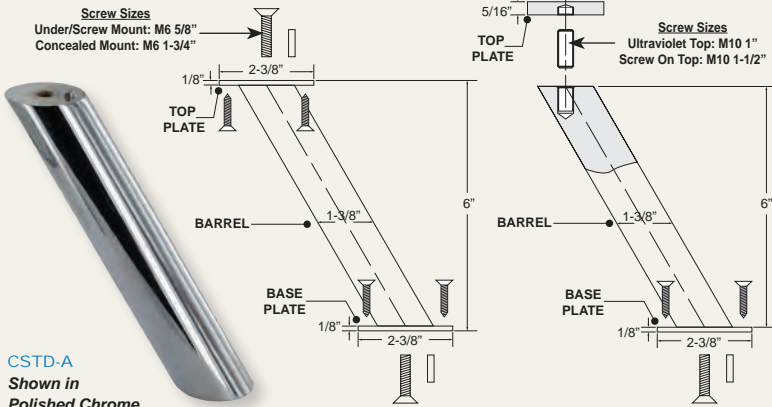

CSTD-A
Shown in
Polished Chrome

15 LB. LOAD CAPACITY EACH

STRAIGHT

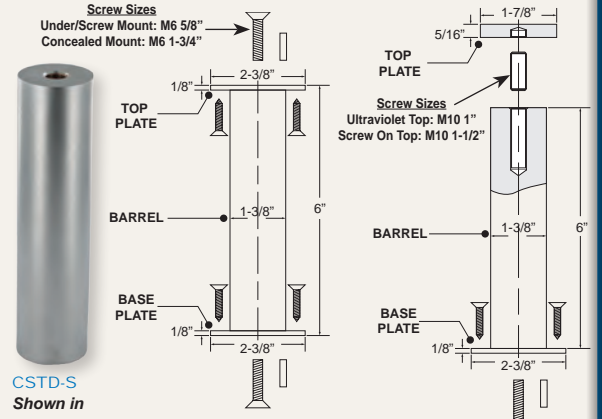

CSTD-S
Shown in
Matte Chrome

30 LB. LOAD CAPACITY EACH

TOP PLATE & BASE PLATE ARE DETACHABLE FROM THE BARREL. ALL RELEVANT MOUNTING PLATES & SCREWS ARE INCLUDED.

2

Choose Top Mount/Top Plate

Ultraviolet Code=U

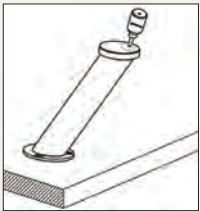

Apply UV Adhesive
To Top

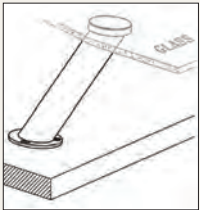

Place Glass on Top &
Let UV Adhesive Cure
(Use a UV light
to cure adhesive)

Screw On Code=T

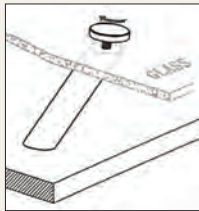

1. Drill Hole
2. Screw Top To Barrel

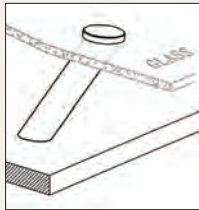

Finished Product

Under Mount Code=S

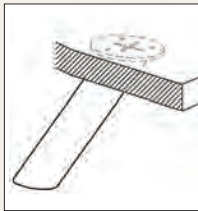

Screw On To Wood Top

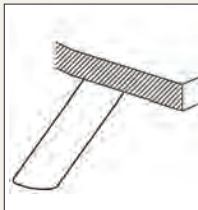

Finished Product

3

Choose Base Mounting Style

Screw Mount Code=88

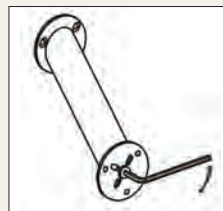

Secure Bottom Plate to Barrel

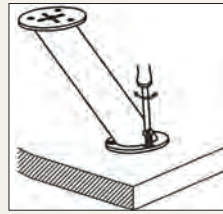

Attach Bottom Plate
to Countertop

Concealed Mount Code=44

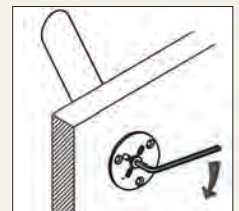

1. Comes With 1-3/4\"/>

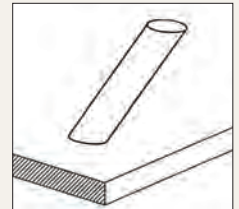

Finished Product

4

Choose A Finish



Polished Chrome
Code=PC



Matte Chrome
Code=MC

PART #	1 BARREL TYPE	2 TOP STYLE	3 BASE STYLE	4 FINISH	
CSTD-A-U-44*	Angled	Ultraviolet	Concealed	*PC= Polished Chrome	
CSTD-A-U-88*	Angled	Ultraviolet	Surface		
CSTD-A-T-44*	Angled	Screw On	Concealed		
CSTD-A-T-88*	Angled	Screw On	Surface	*MC= Matte Chrome	
CSTD-A-S-44*	Angled	Under Mount	Concealed		
CSTD-A-S-88*	Angled	Under Mount	Surface	*PC= Polished Chrome	
CSTD-S-U-44*	Straight	Ultraviolet	Concealed		
CSTD-S-U-88*	Straight	Ultraviolet	Surface		
CSTD-S-T-44*	Straight	Screw On	Concealed		
CSTD-S-T-88*	Straight	Screw On	Surface		*MC= Matte Chrome
CSTD-S-S-44*	Straight	Under Mount	Concealed		
CSTD-S-S-88*	Straight	Under Mount	Surface		

UV GLASS SUPPORTS

New



Material: Aluminum

Finish: Polished Chrome & Matte Chrome

Angled

Requires ultraviolet adhesive and lamp - see page 138

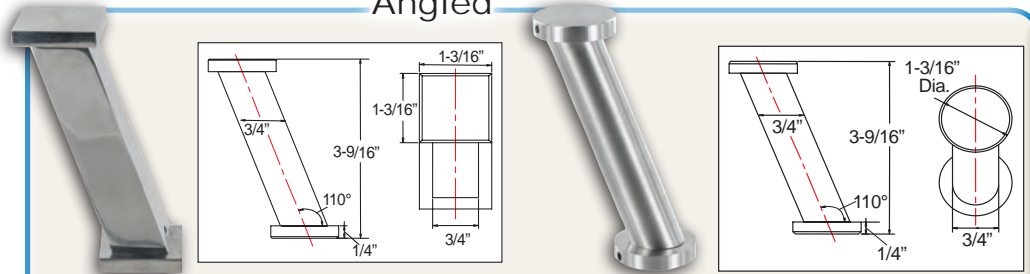

Load Capacity: 55 lbs. per 4 standoffs
maximum counter top size is 39" wide x 23" deep x 5/16" thick

PART #	SHAPE
CSTV-SQ20-A-*	Square
CSTV-RD20-A-*	Round

- Two Shapes available, round and square
- Two styles available, straight & angled
- Hex Key included 1 per order

FINISHES AVAILABLE

Polished Chrome
Code=**PC***

Matte Chrome
Code=**MC***

Straight

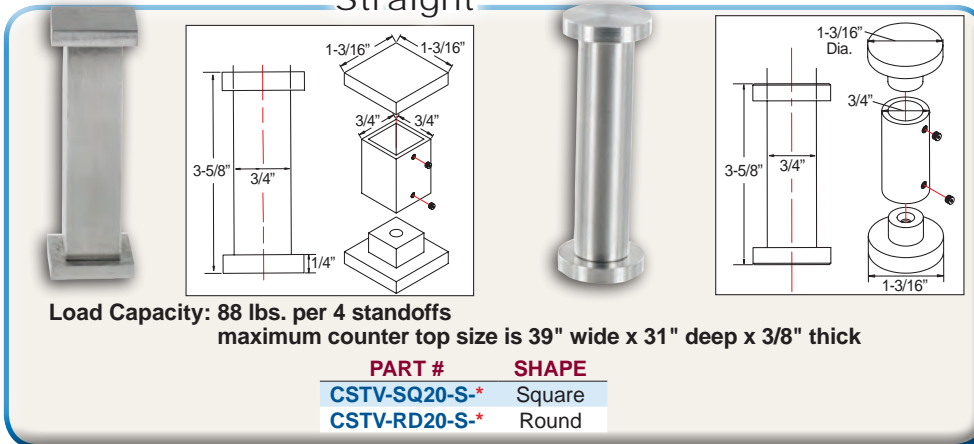

Load Capacity: 88 lbs. per 4 standoffs
maximum counter top size is 39" wide x 31" deep x 3/8" thick

PART #	SHAPE
CSTV-SQ20-S-*	Square
CSTV-RD20-S-*	Round

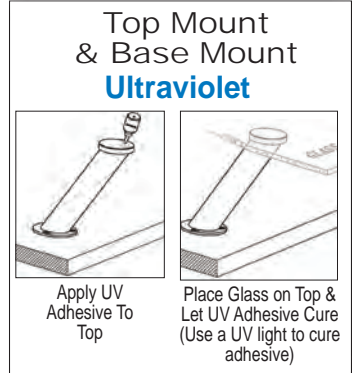

ECONOMY COUNTERTOP SUPPORTS

New

Material: 202 Grade Stainless Steel

Brushed Stainless Finish

- Sleek, Modern look
- Easy to install

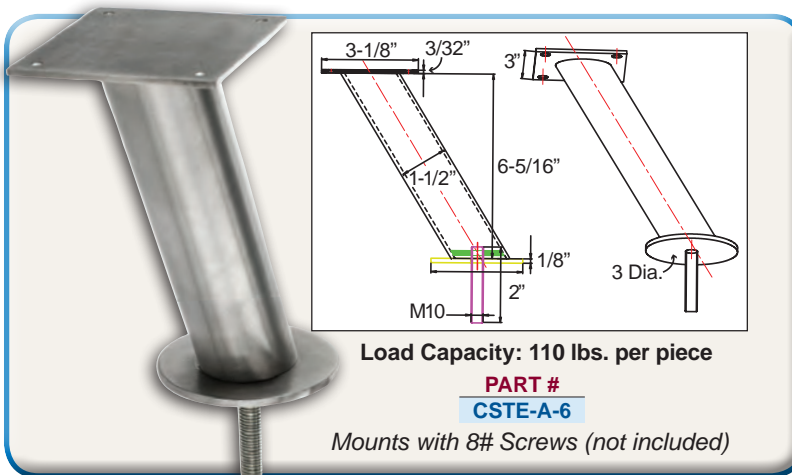

Load Capacity: 110 lbs. per piece

PART #
CSTE-A-6

Mounts with 8# Screws (not included)

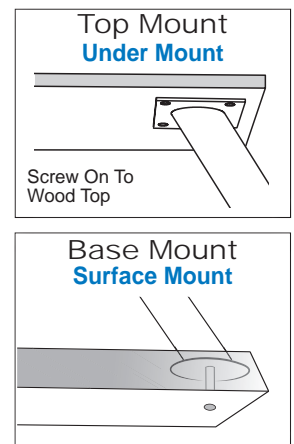

GLASS SHELF SUPPORTS

New

Material: Zinc Alloy

Finish: Polished Chrome & Matte Chrome



- Adjustable to hold glass thicknesses from 1/8" - 1"
- Supports shelves up to 12" deep

SQUARE

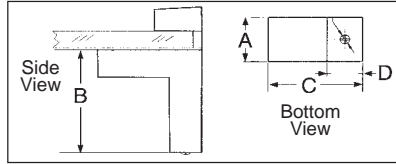

PART #	FINISH	A	B	C	D	HOLDS MATERIAL THICKNESS
GSS-SQ-*	Polished Chrome (PC*) Matte Chrome (MC*)	15/16"	2-5/8"	2-9/16"	11/16"	1/8" - 9/16"



ROUND

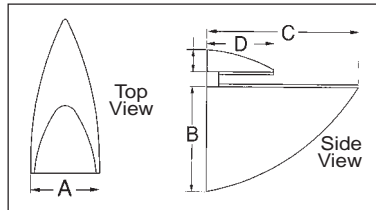

PART #	FINISH	A	B	C	D	HOLDS MATERIAL THICKNESS
GSS-RD1-*	Polished Chrome (PC*)	1"	1-9/16"	2"	3/4"	1/8" - 1"
GSS-RD2-*	Matte Chrome (MC*)	1"	1-7/8"	2-9/16"	1"	1/8" - 1/2"
GSS-RD3-*	Matte Chrome (MC*)	1-3/8"	3"	4"	1-9/16"	1/8" - 1/2"



WALL SHELF SUPPORTS

Material: Steel

Satin Chrome Finish w/Rubber Ring Cushions



- Overall size: 8-1/4"
- 7-3/4" useable size
- 1/2" diameter rod with 7/8" cap

PART #
WSS-200

